



OIL-FIRED MOBILE HOME FURNACE SPECIFICATIONS

MODEL NO.	OME-72D36 / OME-72T36	
	LOW FIRE	HIGH FIRE
HEAT INPUT RATE (BTUH)	70,000	85,000
OUTPUT (BTUH) ¹	60,000	72,000
SEASONAL EFFICIENCY ²	86%	86%
FUEL	#2 FUEL OIL	
NOMINAL TEMP. RISE	66°	
CASING HEIGHT (IN.)	57"	
CASING WIDTH (IN.)	18"	
CASING DEPTH (IN.)	24-3/4"	
FLUE DIAMETER (IN.)	4"	
NOMINAL FLUE OUTLET DIAMETER (IN.)	4"	
APPROX. SHIPPING WEIGHT (LBS.)	240 LBS.	
APPROVAL AGENCY	ETL	
SIZE OF PERM. FILTER	18" X 24"	
ELECTRICAL REQUIREMENTS	115 VAC / 60 HZ / 1 PHASE	
MAX FUSE SIZE	15 AMPS	
TOTAL RATED CURRENT AMPS.	11	
SUPPLY AIR OUTLET SIZE (W-IN X D-IN)	12" X 12"	
RETURN AIR INLET OPENING SIZE	14" X 22" (LOUVERED)	
NOMINAL HEAT ANTICIPATOR SETTING	0.2mA	
	ACCESSORY ITEMS	
MOBILE HOME BASE	70-BASE	
COTTAGE BASE	01COT-BASE	
COIL CABINET FOR 2 TON	CE111S	
COIL CABINET FOR 2.5 & 3 TON	CE211T	
ROOF JACK 12" OR LESS	TRJ-1	
ROOF JACK 13" TO 24"	TRJ-2	
ROOF JACK 25" TO 36"	TRJ-3	
VENT PIPE	VP-1	
SLOPE ADAPTOR 2-1/2-12	TSA-25	
SLOPE ADAPTOR 3-1/2-12	TSA-30	
COMBUSTION AIR INTAKE HOOD	AOPS7402	
TRANSITION BOOT w/ SCREEN	AOPS8419	
BLOCKED VENT KIT ³	AOPS2686	
ROOF JACK COMBUSTION AIR KIT	AOPS7512	
OFFSET VENT KIT	AOPS7518	

¹ OUTPUT BTUH BASED ON ANNUAL FUEL UTILIZATION EFFICIENCY RATED BY MANUFACTURER.

² SEASONAL EFFICIENCY (ALSO CALLED AFUE-ANNUAL FUEL UTILIZATION EFFICIENCY) RATINGS ARE BASED ON TESTS FOLLOWING U.S. DEPARTMENT OF ENERGY TEST PROCEDURES.

³ NOT TO BE USED IN MOBILE HOME APPLICATIONS WITH A ROOF-JACK.

- SEE NEXT PAGE FOR MORE DATA -

OIL-FIRED MOBILE HOME FURNACE SPECIFICATIONS

Model Number Digit	1	2	3	4	5		6	7	8
	Fuel	Mobile Home	Version		Output	Output	Motor Type	Clg Airflow Cap	Clg Airflow Cap
Furnace Model Nomenclature Example Model Numbers	O	M	E	-	7	2	D	3	6
	O	M	E	-	7	2	T	3	6
Fuel: O = Oil Furnace	O								
M = Mobile Home		M							
E = Version			E						
				-					
Output Capacity MBTUH (1000)					7	2			
Motor Type: D = PSC, T = CTM (Constant torque ECM)							D		
Cooling Airflow Capacity in MBTUH (1000)								3	6

- SEE NEXT PAGE FOR MORE DATA -

OIL-FIRED MOBILE HOME FURNACE SPECIFICATIONS

CLEARANCES TO COMBUSTIBLES

MODEL: OME-72	CLOSET	ALCOVE
FRONT	6"	18"
BACK	0"	0"
SIDES	0"	0"
ROOF JACK	0"	0"
VENT CONNECTOR	6"	6"
TOP	1"	1"
PLENUM SIDES	1"	1"
TOP AND SIDES OF DUCT	1"	1"
BOTTOM DUCT	1"	1"

BLOWER DATA

FURNACE MODEL	OME-72D36	OME-72T36
BLOWER MODEL	12-9T	12-9T
MOTOR H.P.	½ HP	½ HP
NO. OF SPEEDS	4	5
HIGH SPEED AIRFLOW (SCFM) @ 0.5 IN. W.G. EXTERNAL STATIC PRESSURE	1195	1189
DIAMETER X WIDTH	12 x 9	12 x 9

BURNER DATA

FURNACE MODEL	OME-72
BURNER MODEL	BECKETT AFG
SPEC. NO	TP-1406
AIR TUBE LENGTH	3"
HEAD	F-3
NOZZLE	0.50x80°A / 0.60x80°A *
REFRACTORY	ISOFORM (SOFT CHAMBER)
PUMP PRESSURE (PSIG)	120

* NOZZLE INSTALLED IN BURNER AS SHIPPED.

- SEE NEXT PAGE FOR MORE DATA -

OIL-FIRED MOBILE HOME FURNACE SPECIFICATIONS

OME-72D36

ALTERATIONS REQ'D FOR A/C @ DESIGN EXTERNAL STATIC PRESSURE			
COOLING UNIT	HTG Speed by Input		Recommended CLG Speed
	Low Fire	High Fire	
24,000	Low	ML	Med Low
30,000	Low	ML	Med High
36,000	Low	ML	High

Speed Tap\ Static Pressure	Furnace Airflow (CFM) vs. External Static pressure (in. WC.)						
	0.1	0.2	0.3	0.4	0.5	0.6	0.7
Low	849	809	768	724	677	627	512
ML	1011	971	923	887	849	776	724
MH	1227	1200	1156	1145	1092	1004	923
High	1492	1443	1397	1354	1295	1195	1092
Blower Motor Current Draw / Power (Amps / Watts) vs. External Static pressure (in. WC.)							
Low	3.2 / 309	3.2 / 310	3.0 / 297	2.9 / 292	2.8 / 285	2.7 / 280	2.6 / 271
ML	4.0 / 400	4.0 / 394	3.9 / 386	3.7 / 374	3.5 / 364	3.4 / 352	3.3 / 343
MH	4.9 / 508	4.8 / 497	4.6 / 481	4.5 / 472	4.3 / 455	4.0 / 429	3.8 / 415
High	5.8 / 618	5.7 / 607	5.5 / 586	5.3 / 570	5.2 / 554	4.9 / 532	4.7 / 515

Speed Tap\ Static Pressure	High Fire Temperature Rise vs. External Static pressure (in. WC.)						
	0.1	0.2	0.3	0.4	0.5	0.6	0.7
Low	80	84	88	94	100	108	132
ML	67	70	73	76	80	87	94
MH	55	56	59	59	62	67	73
High	45	47	48	50	52	57	62

Speed Tap\ Static Pressure	Low Fire Temperature Rise vs. External Static pressure (in. WC.)						
	0.1	0.2	0.3	0.4	0.5	0.6	0.7
Low	66	69	73	77	82	89	109
ML	55	57	60	63	66	72	77
MH	45	46	48	49	51	56	60
High	37	39	40	41	43	47	51

= Recommended operation range

- SEE NEXT PAGE FOR MORE DATA -

OIL-FIRED MOBILE HOME FURNACE SPECIFICATIONS

OME-72T36

ALTERATIONS REQ'D FOR A/C @ DESIGN EXTERNAL STATIC PRESSURE			
COOLING UNIT	HTG Speed by Input		Recommended CLG Speed (Color)
	Low fire	High Fire	
24,000	Low	Med	Med / ML
30,000	Low	Med	MH
36,000	Low	Med	High

Speed Tap\ Static Pressure	Furnace Airflow (CFM) vs. External Static pressure (in. WC.)						
	0.1	0.2	0.3	0.4	0.5	0.6	0.7
Low	873	807	746	677	602	531	448
ML	1024	975	916	863	812	739	671
MED	1081	1032	980	931	886	1823	757
MH	1175	1138	1091	1041	991	950	887
High	1360	1320	1279	1233	1189	1148	1107
Motor Current Draw (Amps/Watts) vs. External Static pressure (in. WC.)							
Low	1.6/111	1.6/116	1.7/121	1.7/126	1.8/130	1.8/135	1.9/141
ML	2.2/166	2.3/172	2.3/178	2.4/183	2.5/189	2.5/195	2.6/200
MED	2.5/193	2.6/200	2.7/206	2.7/212	2.8/217	2.9/224	2.9/230
MH	3.1/246	3.2/250	3.8/257	3.3/263	3.4/269	3.5/275	3.5/282
High	4.4/366	4.5/372	4.5/373	4.6/383	4.7/390	4.7/397	4.8/404

Speed Tap\ Static Pressure	High Fire Temperature Rise vs. External Static pressure (in. WC.)						
	0.1	0.2	0.3	0.4	0.5	0.6	0.7
Low	78	84	91	100	112	128	151
ML	66	69	74	78	83	92	101
MED	63	66	69	73	76	82	89
MH	58	59	62	65	68	71	76
High	50	51	53	55	57	59	61

Speed Tap\ Static Pressure	Low Fire Temperature Rise vs. External Static pressure (in. WC.)						
	0.1	0.2	0.3	0.4	0.5	0.6	0.7
Low	64	69	75	83	93	105	125
ML	55	57	61	65	69	76	83
MED	52	54	57	60	63	68	74
MH	47	49	51	54	56	59	63
High	41	42	44	45	47	49	50

= Recommended operation range

- SEE NEXT PAGE FOR MORE DATA -

OIL-FIRED MOBILE HOME FURNACE SPECIFICATIONS OME-72

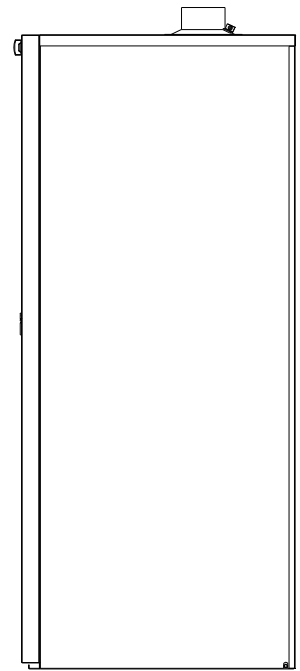
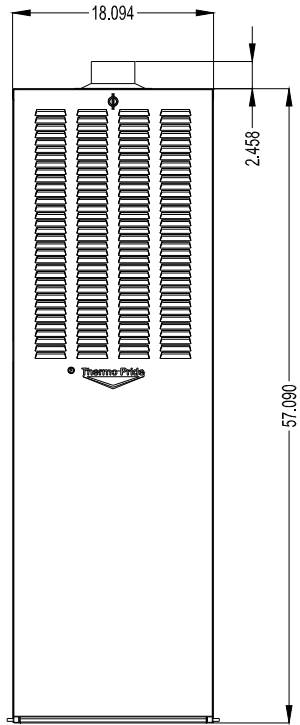
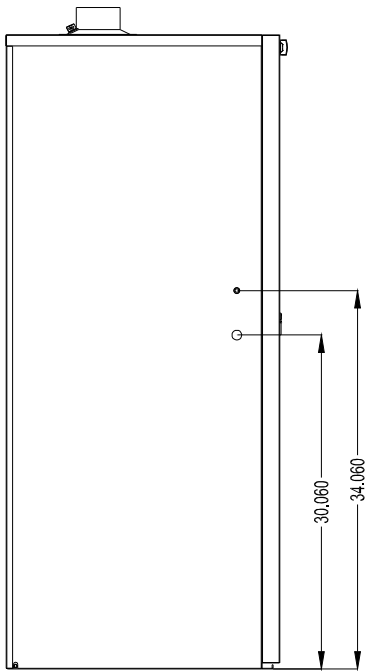
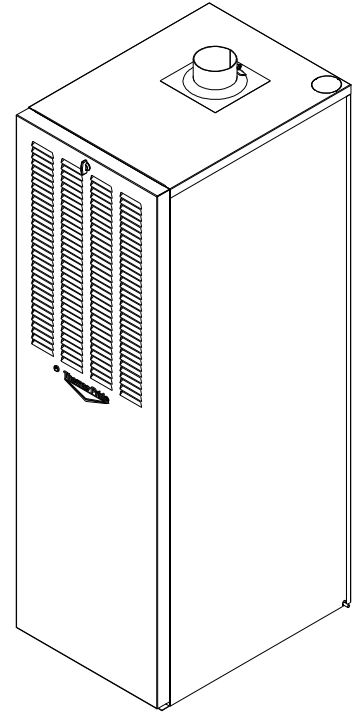
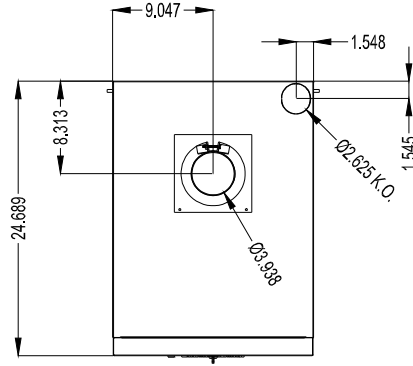
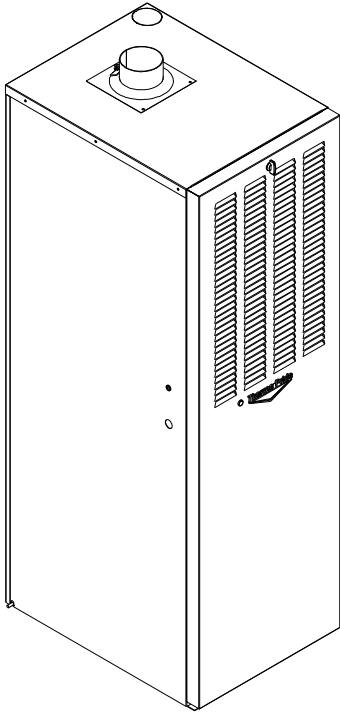

- SEE NEXT PAGE FOR MORE DATA -

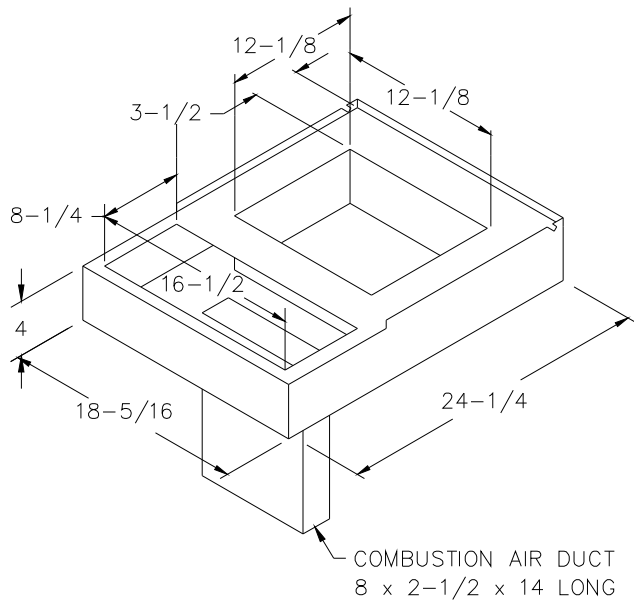

Combustible Floor Base Model: 70-BASE

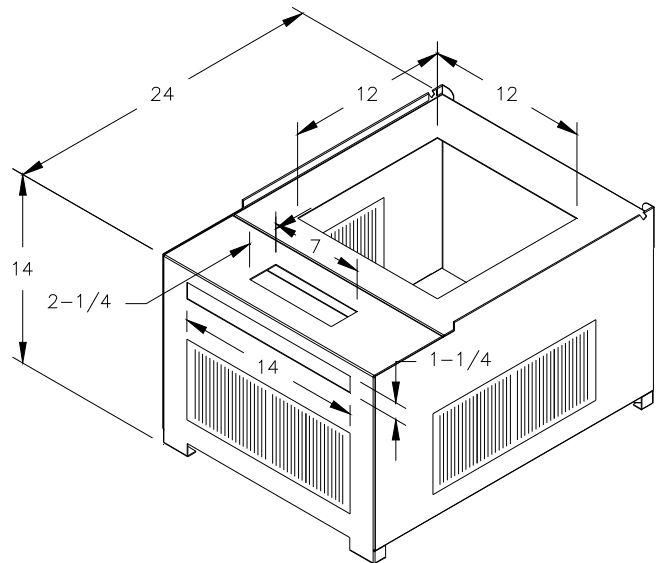

Cottage Base Model: 01COT-BASE

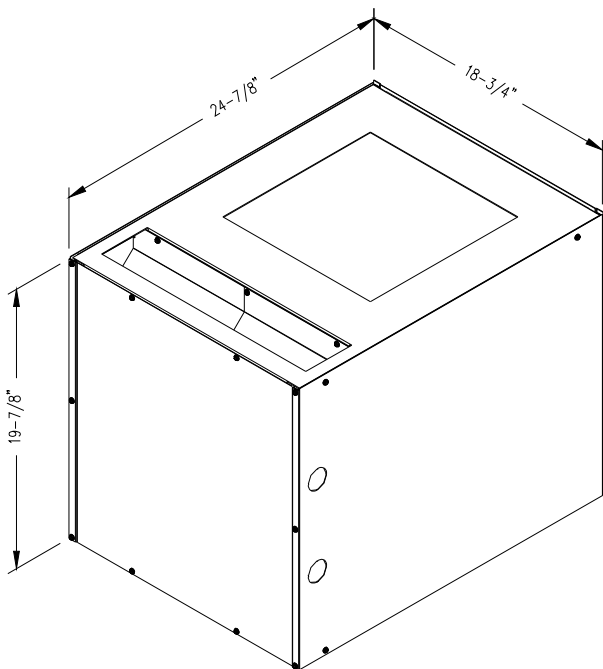

Coil Cabinet Model: CE111S

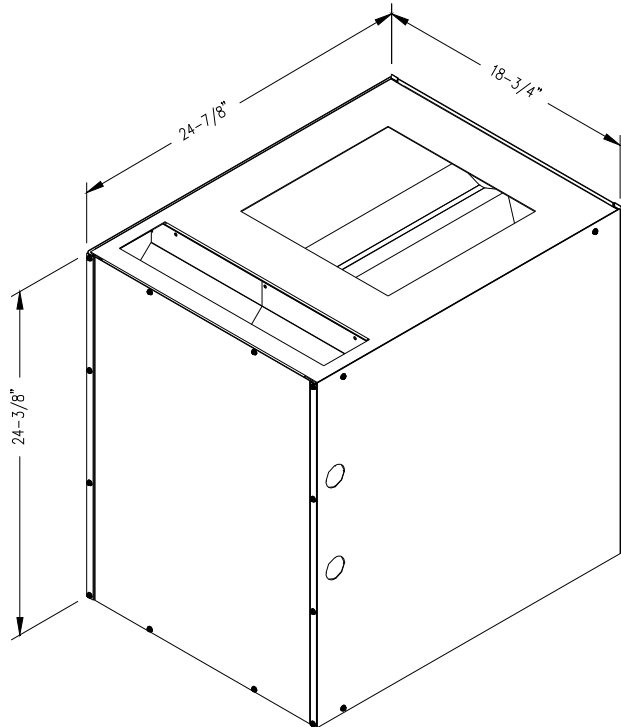

Coil Cabinet Model: CE211T

- SEE NEXT PAGE FOR MORE DATA -

OIL-FIRED MOBILE HOME FURNACE SPECIFICATIONS

A/C EVAPORATOR COIL APPLICATION

FURNACE MODEL	CONDENSER MODEL	LINE SET MODEL	COIL CABINET MODEL	EVAPORATOR COIL MODEL	SEER	EER	TOTAL (BTU/HR) HEAT REMOVAL	SENSIBLE HEAT REMOVAL
OME-72	AC14241G2	LS01E-30 LS01E-50	CE111S/CE113S	13U2430AB15	13.70	11.75	23,600	0.730
			CE111S/CE113S	13U3030AB15	14.00	11.85	23,800	0.733
			CE211T/CE213T	13U3036AB17	14.40	12.15	24,400	0.739
	AC14301G2	LS01E-30 LS01E-50	CE111S/CE113S	13U2430AB15	13.70	11.90	28,000	0.737
			CE111S/CE113S	13U3030AB15	14.00	12.05	28,400	0.739
			CE211T/CE213T	13U3036AB17	14.50	12.40	29,200	0.746
	AC14361G2	LS03E-30 LS03E-50	CE111S/CE113S	13U2430AB15	13.40	11.50	32,600	0.736
			CE111S/CE113S	13U3030AB15	13.70	11.70	33,200	0.740
			CE211T/CE213T	13U3036AB17	14.00	11.95	34,000	0.750

Rev: 9/20/11

SEE NEXT PAGE FOR MORE DATA

OME-72 SPECIFICATIONS

